

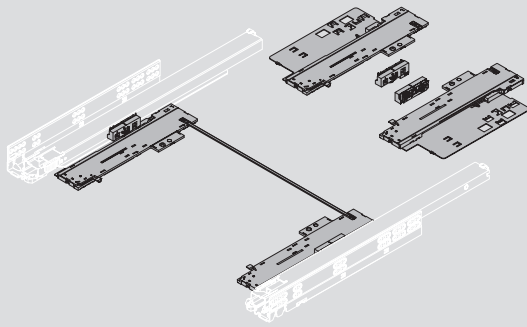

# DYNAPRO TIPMATIC SOFT-CLOSE

Montage / Assembly / Montage / Montaggio / Montaje / Monteringsanvisning / Монтаж

111680 - 06/2020



**Die optimale Schließfunktion von Dynapro Tipmatic Soft-close ist bei einer Schließenergie von 3-5 Joule gegeben.**

The optimal closing function of Dynapro Tipmatic Soft-close is achieved with a closing energy of 3-5 joules.

La fonction optimale de Dynapro Tipmatic Soft-close est atteinte à une énergie de fermeture de 3 - 5 Joule.

La funzione di chiusura ottimale di Dynapro Tipmatic Soft-close è data con un'energia di chiusura di 3-5 joule.

La función de cierre óptima de Dynapro Tipmatic Soft-close se consigue con una energía de cierre de entre 3 y 5 julios.

Optimal funktion hos Dynapro Tipmatic Soft-close uppnås vid en stängnings energi på 3-5 Joule.

Оптимальная функция закрытия Dynapro Tipmatic Soft-close достигается при энергии закрытия от 3 до 5 Дж.

### Erforderliches Zubehör

Required accessories  
Accessoires nécessaires  
Accessorio necessario  
Accesorios necesarios  
Nödvändiga tillbehör  
необходимые комплектующие

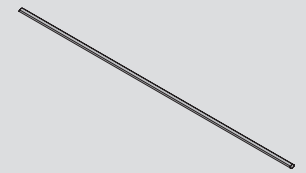

**Wichtiger Hinweis: Montagerihenfolge beachten!** / Important note: parts must be fitted in correct order / Remarque importante: Respecter les différentes étapes de montage / Indicazione importante: seguire l'ordine di montaggio / Nota importante: las partes deben ser encajas en correcto orden / OBS! Detaljerna måste monteras i rätt ordningsföljd / Важное указание: соблюдать последовательность монтажа

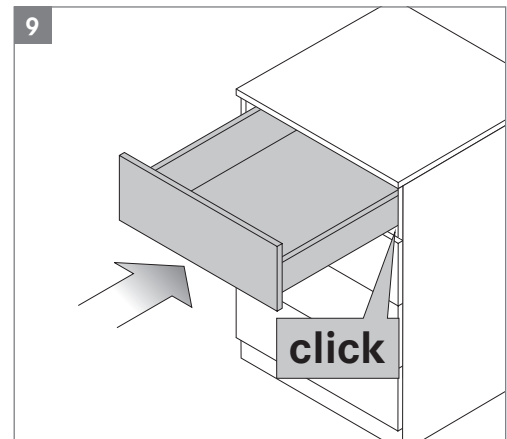
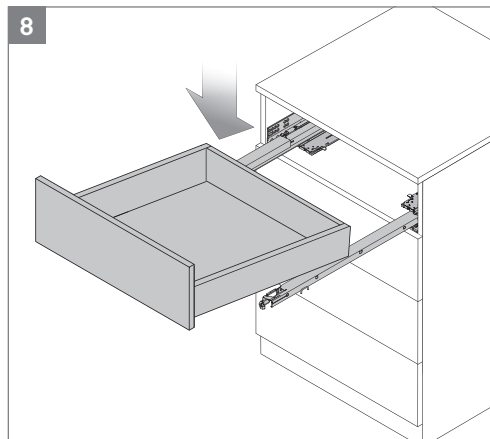
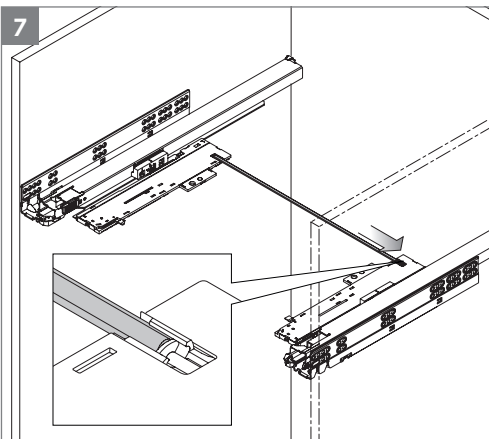
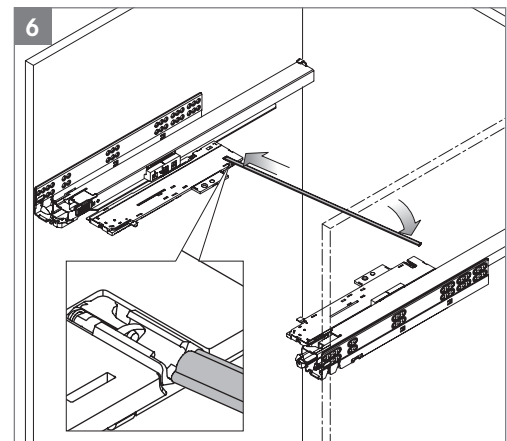
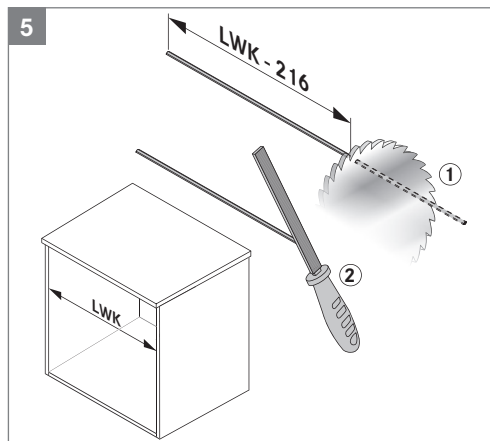
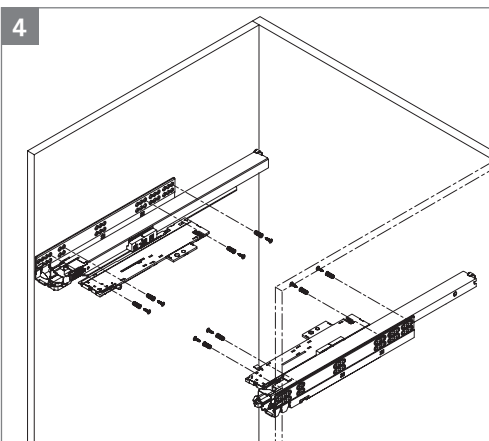
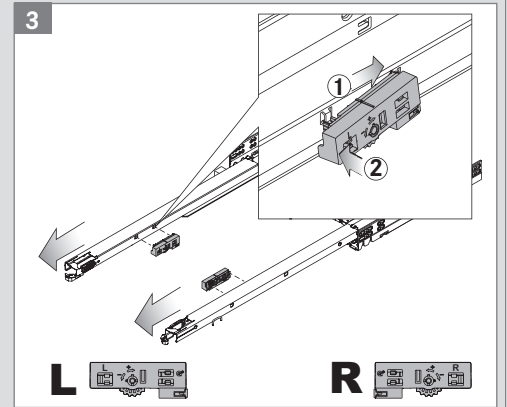
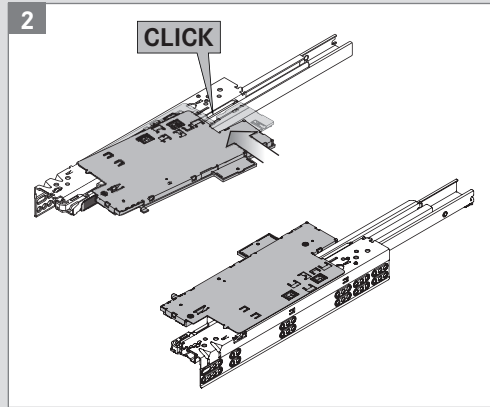
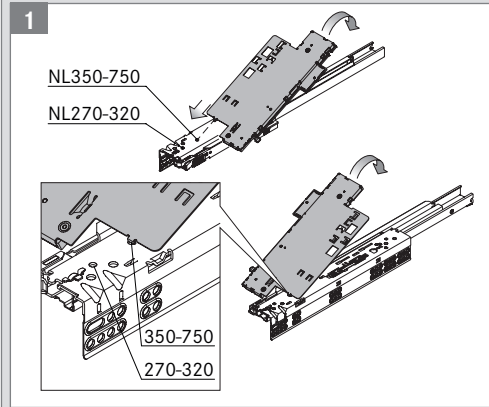

# DYNAPRO TIPMATIC SOFT-CLOSE

Montage/Assembly/Montage/Montaggio/Montaje/Monteringsanvisning/Монтаж

111680 - 06/2020

**Frontspalteinstellung**/Front gap adjustment/Réglage du jeu de façade/Regolazione del gioco frontale/Regulación de la fuga frontal/ Justering av front spalt/Регулировка зазора фасада

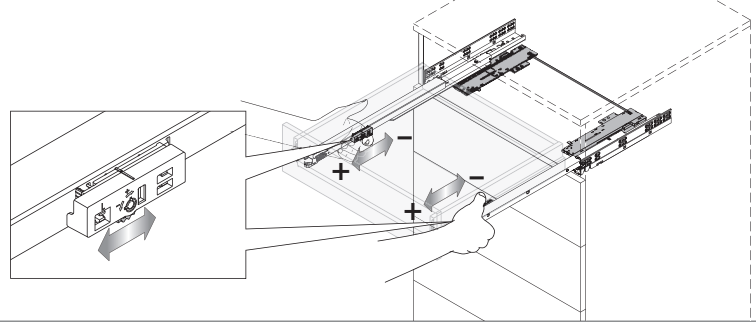
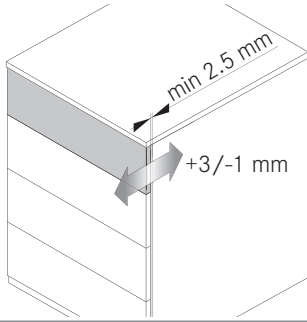

**Auswurfkraft**/Activation force/Force d'ouverture/Forza di sgancio/Fuerza de Activación/Öppningsimpuls/сила выталкивания

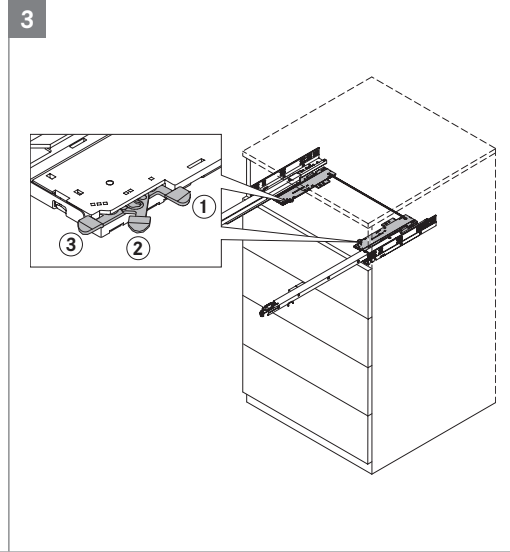
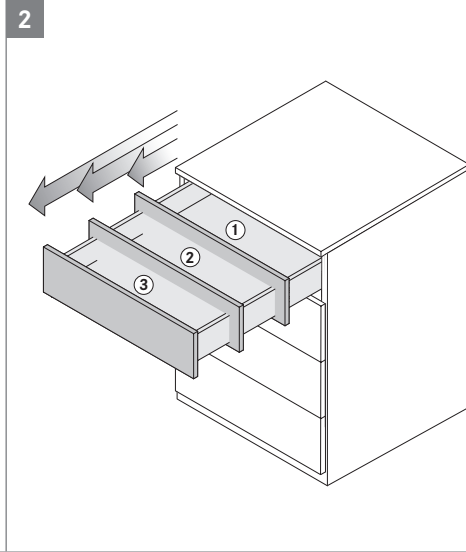
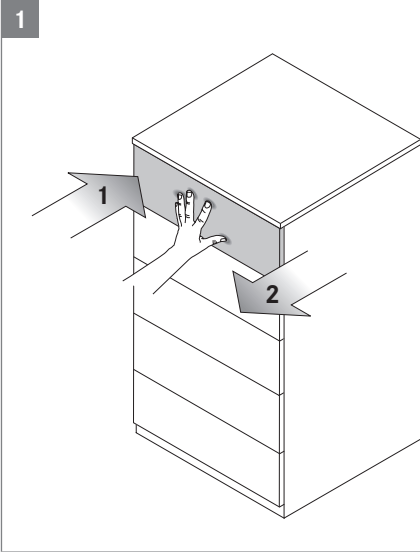

**Wichtige Hinweise**/Important information/Informations importantes/Avvertenze importanti/Indicaciones importantes/Viktig information/Важные примечания

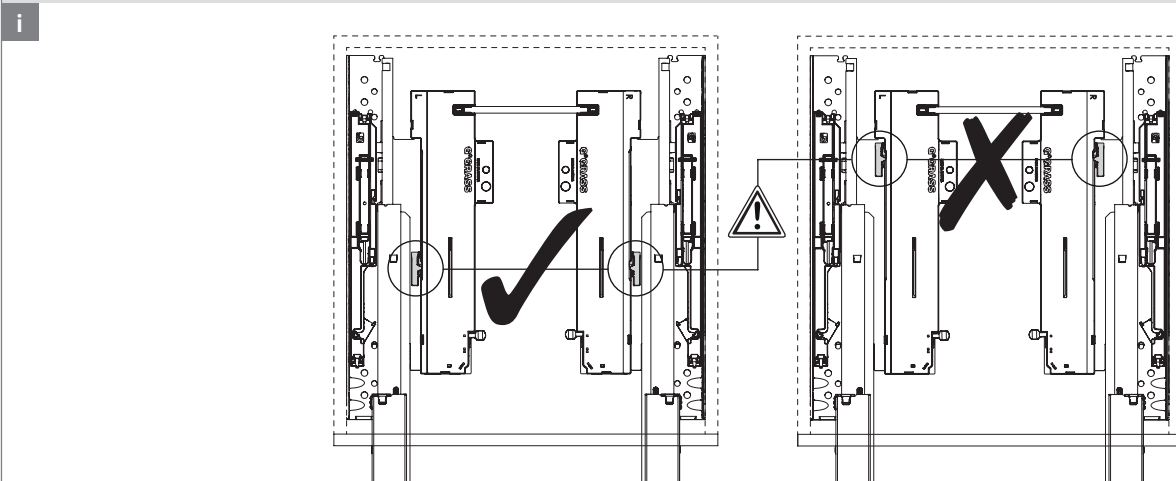

**Wichtige Hinweise**/Important information/Informations importantes/Avvertenze importanti/Indicaciones importantes/Viktig information/Важные примечания

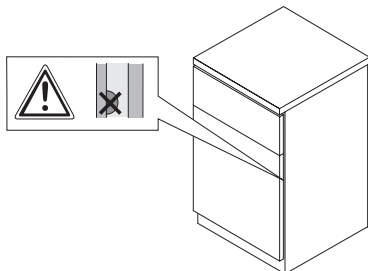

**Transport**/Transport/Transport/Trasporto/Transporte/Transport/Транспортировка

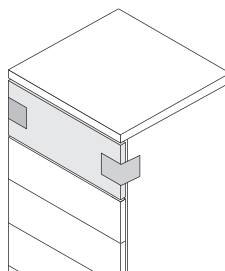

**Auslösbereich**/Activation zone/Zone de déclenchement/Zona di sgancio/Zona de Activación/Öppningsområde/диапазон применения

