

KINVARO D - S

Planungshinweise/Installation information/Instructions de planification/Istruzioni per la progettazione/Indicaciones de planificación

F072135948000 - 10/2017

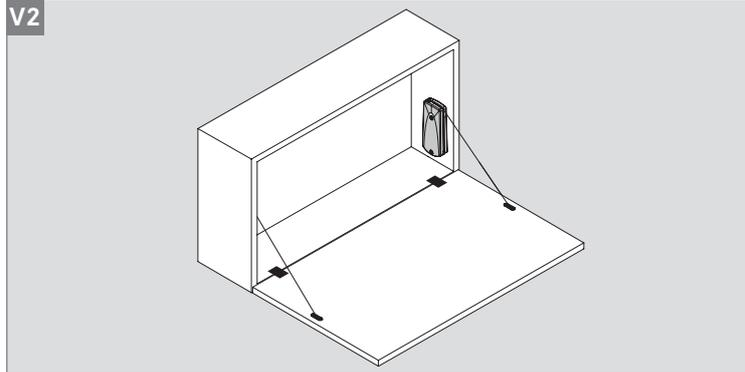
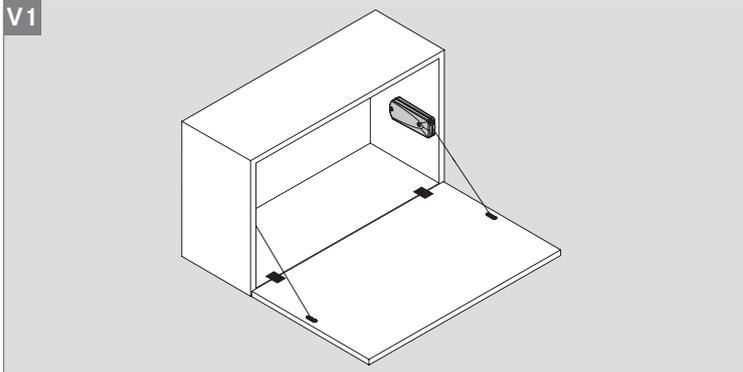

Seitenbohrungen/Side panel drilling/Perçage lateral/Fortura spalla/Taladro costado

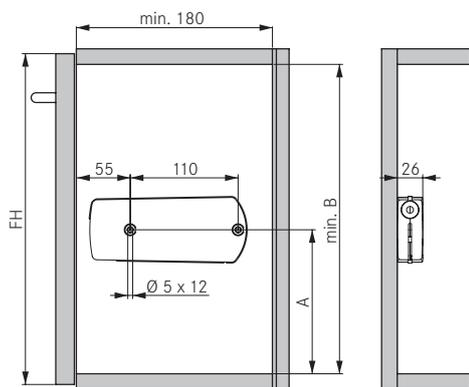

FH	A	B
200 - 270	135	173
270 - 480	148	186

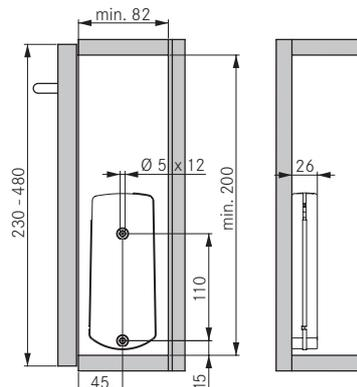

Türbohrungen/Door drilling/Perçage porte/Fortura anta/Taladro puerta

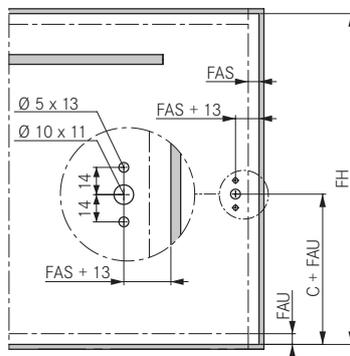

FH	C (V1)	C (V2)
200 - 270	123	123
270 - 480	144	123

Tabellen der Türgewichte/Door weight tables/Tables poids des portes/Tabella pesi anta/Tablones pesos puertas

V1+V2	Feder/Spring/Ressort/Molla/Muelle			
	40N		60N	
FH	Kinvaro D x1	Kinvaro D x2	Kinvaro D x1	Kinvaro D x2
210 - 270	1.7 - 3	3.9 - 4.5	3.1 - 4	7.5 - 8
270 - 330	1.7 - 3	3.3 - 4.5	3.1 - 4	6.1 - 7.4
330 - 380	1.7 - 1.9	3.2 - 3.5	2.9 - 3.5	5.1 - 6.8
380 - 430	1.5 - 1.8	2.7 - 3.3	2.5 - 3.3	4.8 - 6.6
430 - 460	1.2 - 1.7	2.5 - 3.1	2.3 - 3.3	4.6 - 6
460 - 480	-	-	2.2 - 2.8	4.4 - 5.3



Das Gewicht und die Position des Griffes können die Leistung des Mechanismus beeinflussen./The weight and the position of the handle may influence the performance of the mechanism./Le poids de la porte et la position de la poignée sont des facteurs influençant les prestations du mécanisme./Il peso e la posizione della maniglia possono influenzare le prestazioni del meccanismo./El peso y el posicionamiento del tirador pueden afectar las prestaciones del mecanismo.

KINVARO D - S

Montage / Assembly / Montage / Montaggio / Montaje

F072135948000 - 10/2017

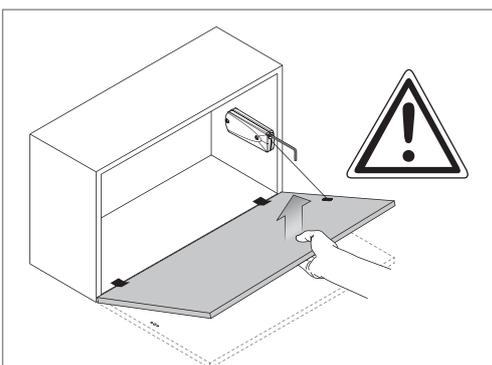
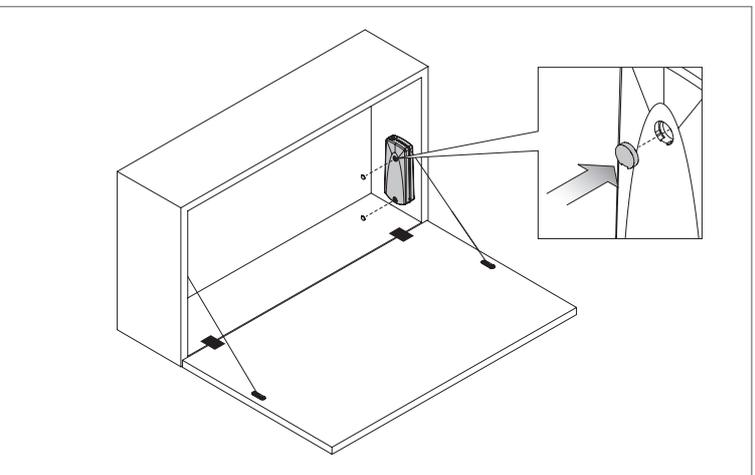
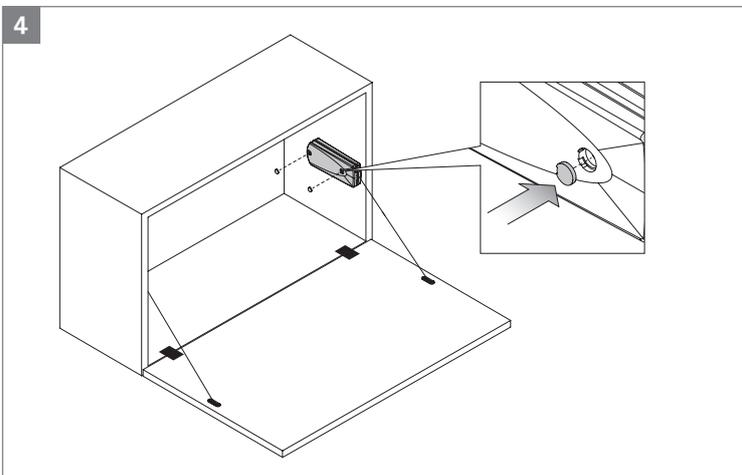
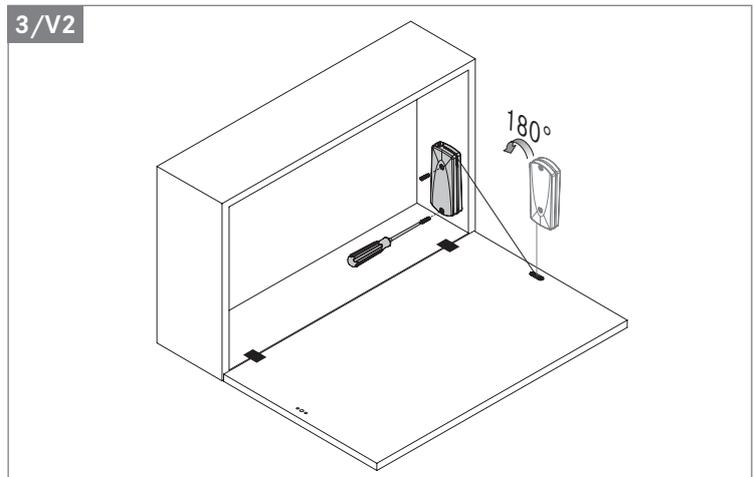
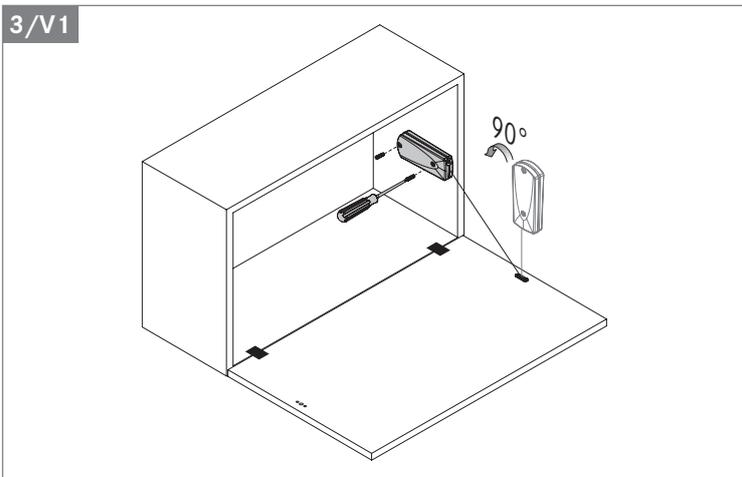
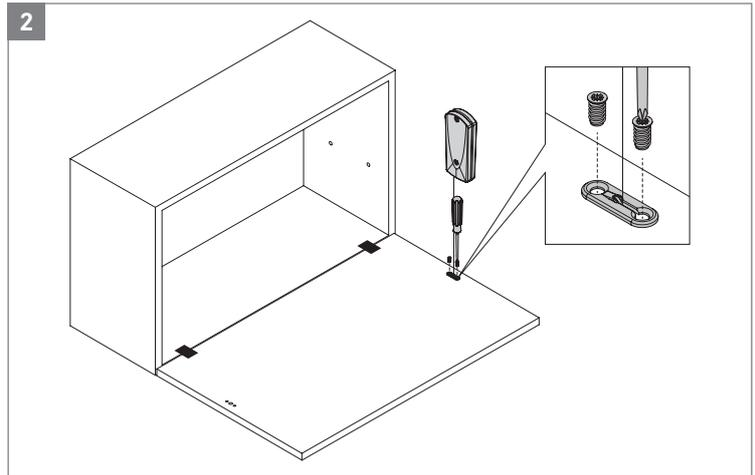
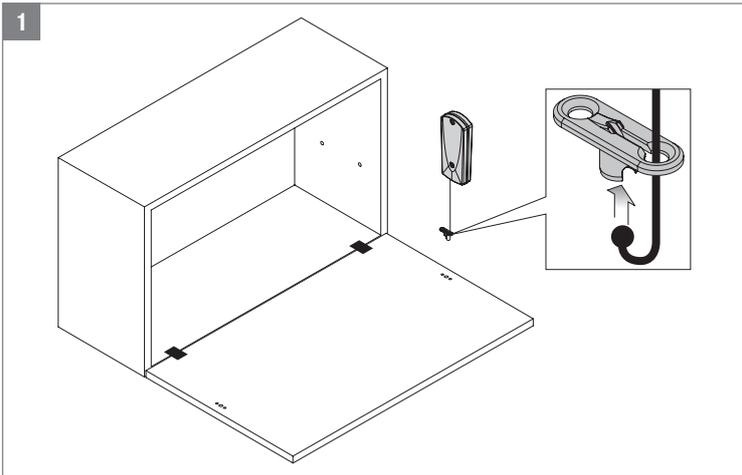

Während der Einstellung Türgewicht erleichtern / Lighten up door during the adjustment / Alléger poids de la porte pendant le réglage / Scaricare peso anta durante la regolazione / Aligerar peso de la puerta durante el ajuste

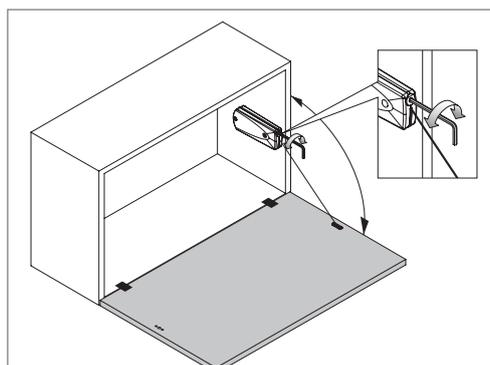

Einstellung des Öffnungswinkels / Opening angle adjustment / Réglage de l'angle d'ouverture / Regolazione angolo di apertura / Regulación del ángulo de apertura

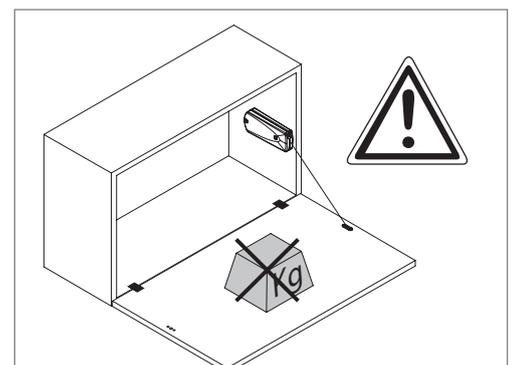

Die Tür nicht mit Zusatzgewichten laden / Do not load the door with additional weights / Ne chargez pas la porte avec poids supplémentaires / Non caricare l'anta con pesi aggiuntivi / No cargue la puerta con pesos adicionales